

**Installation Instructions for ASHCROFT®
Explosion Proof Differential Pressure
Gauge/Switch, Variation XEK
Types 1130, 1131, 1132**



For efficient working of your gauge, please read all instructions carefully before attempting to install.

CAUTION: Do not exceed maximum operating pressure given on the gauge label. Check fluid compatibility with wetted parts before use.

OPERATING PRINCIPLE

Variations in pressure between high and low ports is sensed by a piston or diaphragm sensor ① which moves in proportion to the pressure difference. A primary magnet ② is attached to the sensor and moves with it in the same proportion. A rotary magnet ③ with pointer is magnetically coupled with the primary magnet, and is situated in an isolated cavity. Movement of rotary magnet with pointer indicates differential pressure on the dial. Process fluids are isolated from dial case and switch enclosure.

SWITCH: An auxiliary magnet ④ situated in the tube extension moves with the pressure sensors. Reed switches mounted on the extension tube are activated due to interaction between switch contacts and field of the auxiliary magnet. Switches can be adjusted to open or close at preset points.

Note: The gauges are calibrated to give $\pm 2\%$ full scale accuracy on ascending readings.

INSTALLATION

Depressurize the system and connect the high and low pressure lines of your system to the "High" and "Low" ports of the gauge, respectively.

Apply "High" and "Low" pressures simultaneously, to avoid damage to the internal parts. If pressure exceeds the rated maximum pressure, "O" rings used on male connectors, and the teflon seal inside the pressure chamber of piston instrument will be damaged. In diaphragm instrument diaphragm may rupture. If maximum operating pressure is within the allowable limit, but the differential pressure exceeds gauge range, there will be no damage to the gauge. Pointer will only go the extreme right end of the scale.

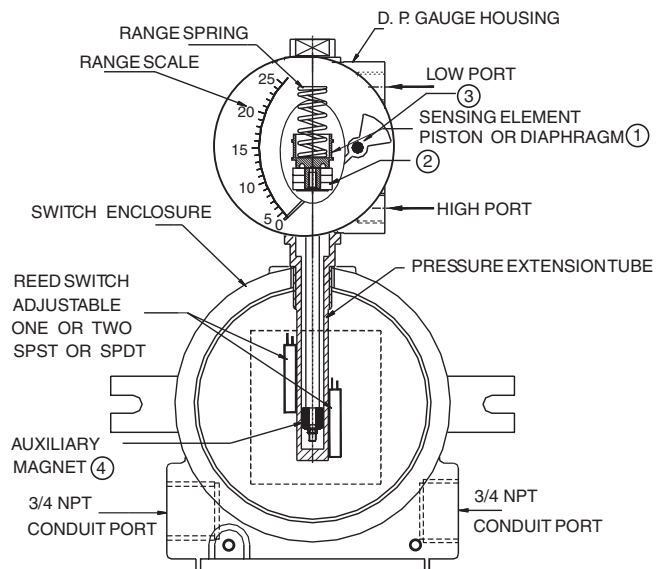

EXPLOSION PROOF SWITCH INFORMATION

Switches and electrical connections are mounted in an explosion proof enclosure with UL, CSA, FM and CENELEC approval. The enclosure meets Class 1, Groups B, C, D, Class 2, Groups E, F, G, Class, NEMA 7 & 9 and IP66. There are two 3/4" electrical conduit connections.

PRECAUTIONS

Do not connect "High" and "Low" ports to wrong pipe ends. Do not subject the gauge to excessive vibration. The gauge is never to be used in an area where a magnetic field is present. It may affect readings.

As the gauge works on magnetic coupling principal, use only non magnetic fittings, parts etc. in areas closer than 2" on all sides, otherwise calibration will be affected.

Do not try to open any part of the gauge for any reason, because if not reassembled properly, calibration and operation will be affected.

**Installation Instructions for ASHCROFT®
Explosion Proof Differential Pressure
Gauge/Switch, Variation XEK
Types 1130, 1131, 1132**



SWITCH SETTING

The switches are normally factory set to save time at customer end. However, they are field adjustable.

CAUTION: Supply voltage should not exceed switch rating. For higher voltages, the use of relay circuit is recommended.

SWITCH ADJUSTMENT

The following procedure can be done by putting the gauge on a test bench or while in service.

Unscrew the cover of the electrical enclosure. Knurled head set screws are provided at bottom for setpoint adjustment .

Rotate the screw clockwise (right) to decrease the setpoint and counter-clockwise (left) to increase the setpoint.

One or two trials may be necessary to attain the exact setpoint.

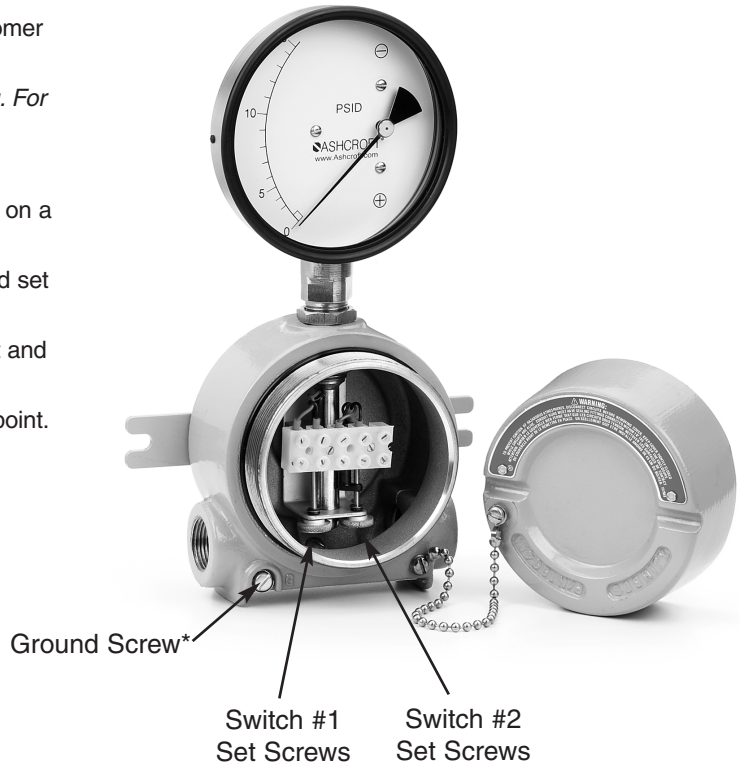

SPST SWITCH

Specifications

Contact Rating : 10 VA ac (rms) or dc (max)
Switching Current : 0.5 Amp ac (rms) or dc (max)
Switch Voltage : 100 Vac/Vdc (max)

SPDT SWITCH

Specifications

Contact Rating : 3 VA ac (rms) or dc (max)
Switching Current : 0.3 Amp ac (rms) or dc (max)
Switch Voltage : 30 Vac/Vdc (max)

**ONE SPST SWITCH
Reed Switches and
Terminal Strip Connection**

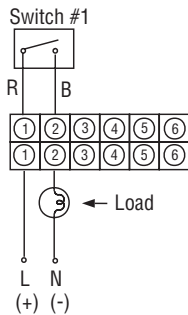

**TWO SPST SWITCHES
Reed Switches and
Terminal Strip Connection**

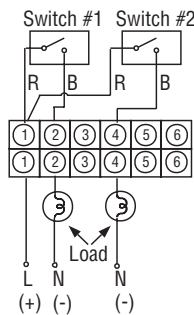

**ONE SPDT SWITCH
Reed Switches and
Terminal Strip Connection**

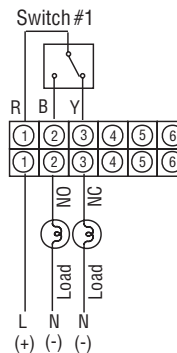

**TWO SPDT SWITCHES
Reed Switches and
Terminal Strip Connection**

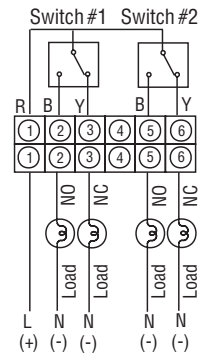

R = Red; B = Black; Y = Yellow; L = Live or + Supply; N = Neutral or - Supply.

*Use ground screw to ground enclosure.