

Third angle projection

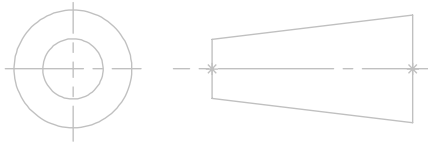

This drawing includes confidential information which is the property of ASHCROFT INC. This copy is loaned for the specific purpose, with the understanding that it will not be reproduced or used for any other purpose or disclosed to others, and it will be returned on demand.

ASHCROFT INC.
250 EAST MAIN STREET,
STRATFORD, CT 06614

REV	ECO	DESCRIPTION	BY	DATE
A	9618	INITIAL RELEASE	JDB	10/12/2017

NOTES:-

- VALVE RATING: 6000 PSIG - CLASS 2500
- HYDROTEST PRESSURE: 9000 PSIG
- ALL DIMENSIONS IN mm UNLESS SPECIFIED OTHERWISE
- VALVE SHALL BE STAMPED WITH FOLLOWING INFORMATION:
 - ASHCROFT
 - 25V015VFSS86/A
 - MOC: 316/316L SS
 - NPT (F) X NPT(F)
 - T. PR. 9000 PSI @100° F
 - W. PR 6000 PSI @100° F
 - H. CODE:
- BLUE DUST CAP SHALL BE ON ISOLATION VALVE HANDLE
RED DUST CAP SHALL BE ON DRAIN/VENT VALVE HANDLE,
GREEN DUST CAP SHALL BE ON EQUALIZER VALVE HANDLE

PARTS LIST			
ITEM	QTY	PART DESCRIPTION	MATERIAL
1	1	BODY	SS 316/316L
2	5	GLAND BODY	SS316/316L
3	5	GLAND RETAINER	SS304
4	10	GLAND SEAL	P.T.F.E
5	5	CHECK NUT	SS304
6	5	SPINDLE	SS316/316L
7	5	TRIM	SS316/316L
8	5	HANDLE	SS 304
9	5	WASHER	SS
10	5	LOCK PIN	SS 304
11	5	DUST CAP	PVC
12	2	DRAIN PLUG 1/4 NPT	SS316/316 L
13	2	SWIVEL GAUGE ADAPTOR 1/4" NPT(M) X 1/4" NPT(M)	SS316/316 L

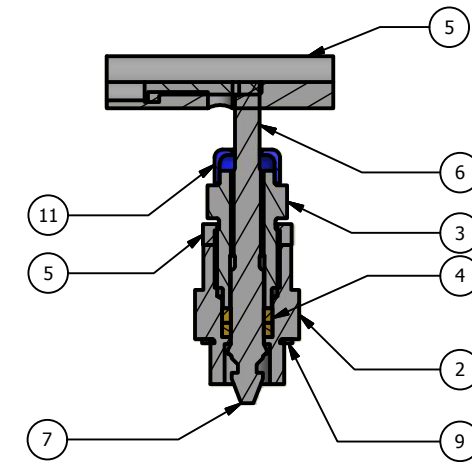
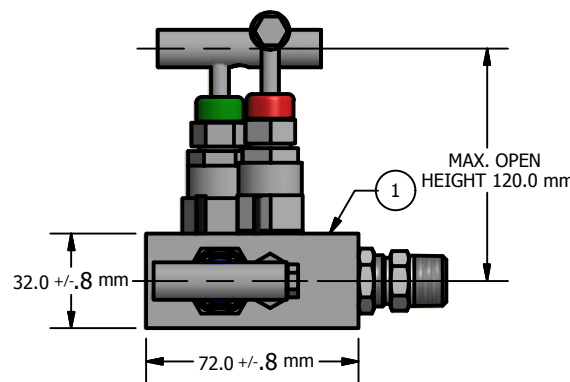
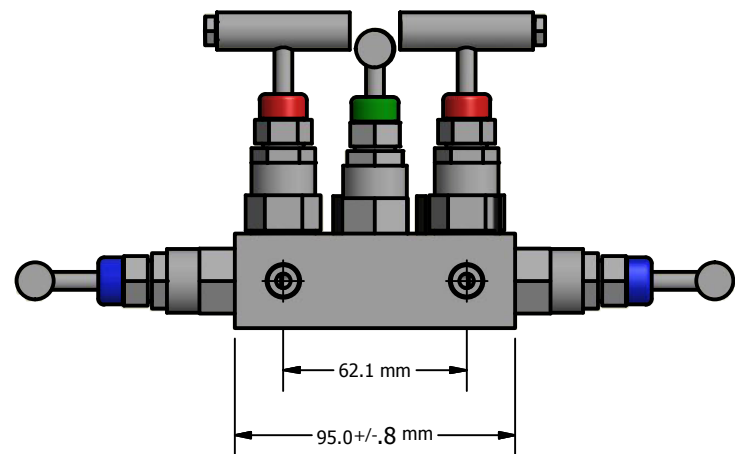
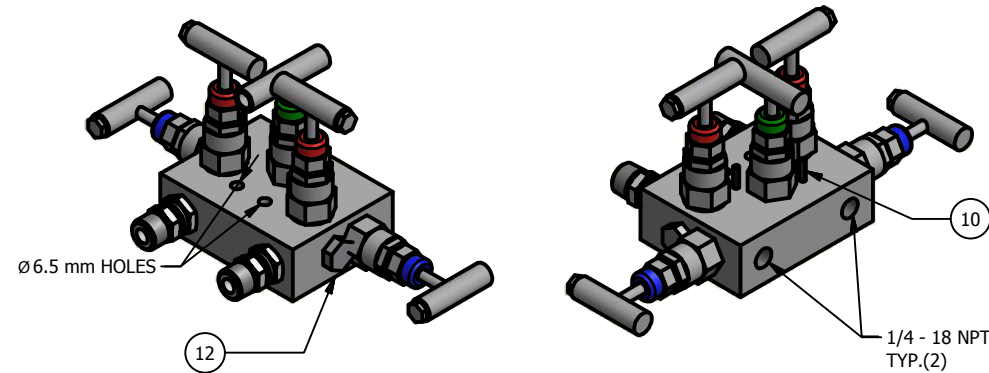
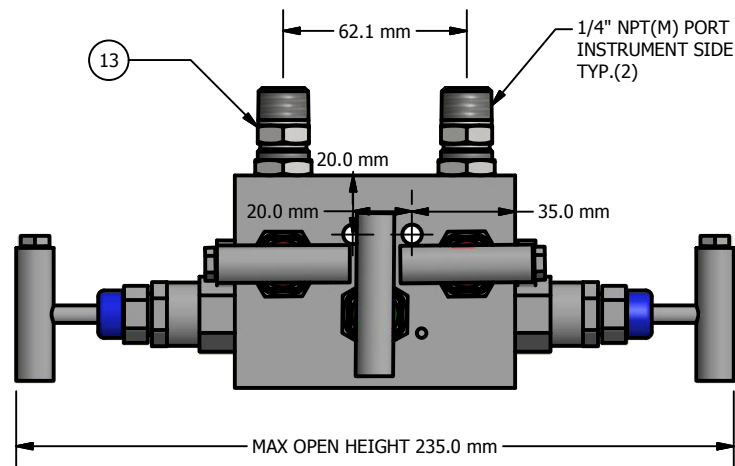

This print certified correct for		General Dimensions		
Customer's Name		25V015VBSS86/A		
		5 VALVE MANIFOLD FLAT TYPE WITH DRAIN		
		NPT(F) X NPT(F)		
Customer's Order No.	Drawn	Date	Date of Issue	
Ashcroft Order No.	FATEHJIT	5/26/2017	SHEET-1	
Certified by	Date		070A4287	Rev. A