

Type DG25 General Purpose Digital Gauge



SHOWN WITH OPTIONAL BLACK OR ORANGE PROTECTIVE BOOT



FEATURES:

- 0.5% terminal point accuracy (0.25% optional)
- Five-digit LCD display with large .48" character size
- New bar graph display (20 segment)
- Nine engineering units of measure plus one user programmable unit
- Capable of measuring gauge, vacuum and compound ranges from -14.7 psi through 25,000 psi
- IP67 weatherproof enclosure
- CE compliant, RoHS compliant, UL and cUL 61010-1
- The versatile and economical choice for a wide variety of applications

BENEFITS:

The Ashcroft® DG25 series offers 0.5% of span accuracy. Laser-welded stainless steel sensor and socket make this product suitable for use with a wide variety of pressure media in demanding industrial applications. This series is also available with enhanced accuracy of 0.25% of span making it suitable for many test and measurement uses.

IP67 ingress protection rating means the DG25 is suitable for demanding applications such as equipment wash down.

Comes with nine preprogrammed engineering units of measure to read pressure in units applicable to the process, or a unit familiar to the technician using the gauge.

The DG25 comes standard with many features such as: tare, min and max memory, programmable custom engineering units, and pressure ranges from vacuum to 25,000 psi.

The DG25 was designed with the OEM in mind and can easily be custom configured to meet unique requirements, add or delete features and be customized with private label keypad overlays. Contact Ashcroft or your authorized distributor to discuss your OEM requirements.

PRODUCT SPECIFICATIONS

- Accuracy:** 0.5% F.S. standard, 0.25% optional includes effects of linearity, hysteresis and repeatability
- LCD Display:** Five-digit numeric top line, five-character alphanumeric lower line, 20 segment vertical bar graph, four-segment battery life indicator, dedicated icons for gauge timer, back light timer, tare, min and max
- Character Height:**
Upper line 0.48" (12.19mm),
Lower line 0.24" (6.10mm)

- View Angle:** 12 o'clock
- Backlight:** Optional (Blue Backlight)
- Eng. Units:** psi, bar, inHg, cmHg, mmHg, kPa, mPa, kg/cm², ftH₂O, and customer defined unit
- Ranges:** 45 standard psi and bar ranges from -14.7 to 25000 psi, gauge, vacuum and compound ranges available. Note: not all units are included with all ranges. See range table.
- Resolution (by range):** See chart on pg. 3 for detail by range.
- Enclosure Material:** Case & Back: Polycarbonate/ABS
Window: Polycarbonate
- Enclosure Rating:** IP67
- Protective Boot:** Optional (Black or Orange)
- Serial No.:** Yes
- Nominal Size:** 2.73" (70mm) dia.; 1.61" (40.9mm) deep; 2.64" (67mm) centerline to end of ¼ NPT thread height
- Wetted Matl.:** 17-4 ph sensor & 316L socket, laser welded
- Connection:** ¼ NPT lower standard, Options ½ NPT, G ¼ B, others consult factory; 6 o'clock (lower) position standard; 12 o'clock (upper) position optional (factory set only) (not available with initial release)
- Battery:** Two AA alkaline batteries
- Battery Life:** 2000 hours minimum
- Battery Life Indicator:** 4 levels
- Cycle Life:** 10 million cycles
- Vibration:** MIL-STD-202G, Method 201A
- Shock:** MIL-STD-202G, Method 213B, Test Condition K
- Oper. Temp:** -4°F to 140°F, (-20°C to 60°C) ambient temp.; -4°F to 176°F, (-20°C to 80°C) process media temp
- Storage Temp:** Batteries Installed: -4°F to 140°F, (-20°C to 60°C)
Batteries Removed: -4°F to 176°F, (-20°C to 80°C)
- Temp. Coef.:** 0.04%/°F (-20°F to 180°F) zero and span Reference Temp. 70°F
- Leak Integrity:** 10⁻⁷ std. cc/sec.
- Update Rate:** 1Hz, 2Hz, 4Hz,
- Keypad Functions:** Three key; available with multi press functionality
- Hard Keys:** on/off; Power Symbol and Enter zero; Zero, Tare, and Up Arrow menu Access, Backlight, Down Arrow
- Agency Approvals:** CE (heavy industrial), ASME B40.7, RoHS, UL 61010/ cUL
- Proof Pressure:** Vac - 2,000: 200%
- % of Span**
3,000 - 5,000: 150%
7,500 - 25,000: 120%
- Burst Pressure:** Vac - 2,000: 800%
- % of Span**
3,000 - 5,000: 500%
7,500 - 25,000: 300%

Type DG25 General Purpose Digital Gauge

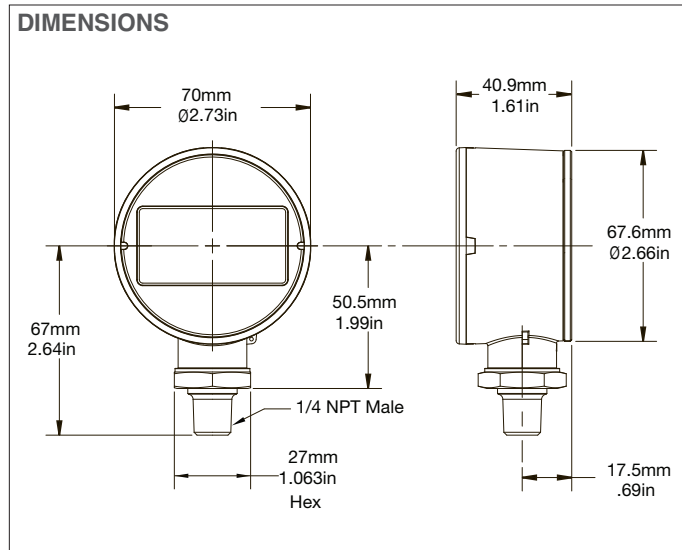

Weight: 6.7 oz. (no boot)
8.4 oz. (boot attached)

How To Order

D	G	25	5	1	L	0	NA	M02	L							-	X																					
CLASS (Digital General Purpose)		SIZE 2.5" Diameter	ACCURACY (3) 0.25% (5) 0.50%	TYPE (1) Battery	BACKLIGHT (L) Backlight (N) No Backlight	PROTECTIVE BOOT (0) None (1) Black (2) Orange	ELECTRICAL CONNECTION (NA) Not Applicable	PRESSURE CONNECTION SIZE (M01) 1/8 NPT Male (M02) 1/4 NPT Male (MG2) G1/4B Male (MGA) G1/4A (F09) 9/16-18UNF-2B int. thd (MD2) 1/4 NPTF male Consult factory for other available pressure connections.	PRESSURE CONNECTION LOCATION (L) Lower (T)* Top (E)* 9 o'clock (D)* 3 o'clock *Not available for initial release	PRESSURE RANGE		<table border="0"> <tr> <td>(15#) 15 psi</td> <td>(3000#) 3000 psi</td> </tr> <tr> <td>(30#) 30 psi</td> <td>(5000#) 5000 psi</td> </tr> <tr> <td>(50#) 50 psi</td> <td>(7500#) 7500 psi</td> </tr> <tr> <td>(60#) 60 psi</td> <td>(10,000#) 10,000 psi</td> </tr> <tr> <td>(100#) 100 psi</td> <td>(15,000#) 15,000 psi</td> </tr> <tr> <td>(150#) 150 psi</td> <td>(20,000#) 20,000 psi</td> </tr> <tr> <td>(200#) 200 psi</td> <td>(25,000#) 25,000 psi</td> </tr> <tr> <td>(300#) 300 psi</td> <td>(0IM&V) 0 inHg/-30 inHg</td> </tr> <tr> <td>(500#) 500 psi</td> <td>(15#&V) 15 psi/-14.7psi</td> </tr> <tr> <td>(750#) 750 psi</td> <td>(30#&V) 30 psi/-14.7psi</td> </tr> <tr> <td>(1000#) 1000 psi</td> <td>(45#&V) 45 psi/-14.7psi</td> </tr> <tr> <td>(2000#) 2000 psi</td> <td>(60#&V) 60 psi/-14.7psi</td> </tr> </table> <p>See table for all standard pressure ranges.</p>		(15#) 15 psi	(3000#) 3000 psi	(30#) 30 psi	(5000#) 5000 psi	(50#) 50 psi	(7500#) 7500 psi	(60#) 60 psi	(10,000#) 10,000 psi	(100#) 100 psi	(15,000#) 15,000 psi	(150#) 150 psi	(20,000#) 20,000 psi	(200#) 200 psi	(25,000#) 25,000 psi	(300#) 300 psi	(0IM&V) 0 inHg/-30 inHg	(500#) 500 psi	(15#&V) 15 psi/-14.7psi	(750#) 750 psi	(30#&V) 30 psi/-14.7psi	(1000#) 1000 psi	(45#&V) 45 psi/-14.7psi	(2000#) 2000 psi	(60#&V) 60 psi/-14.7psi	OPTIONAL X-VARIATIONS (XB3) Pouch with Logo (X6B) Cleaned For Oxygen Service (XC4) Individual Calibration Chart (XNH) Wired SS Tag
(15#) 15 psi	(3000#) 3000 psi																																					
(30#) 30 psi	(5000#) 5000 psi																																					
(50#) 50 psi	(7500#) 7500 psi																																					
(60#) 60 psi	(10,000#) 10,000 psi																																					
(100#) 100 psi	(15,000#) 15,000 psi																																					
(150#) 150 psi	(20,000#) 20,000 psi																																					
(200#) 200 psi	(25,000#) 25,000 psi																																					
(300#) 300 psi	(0IM&V) 0 inHg/-30 inHg																																					
(500#) 500 psi	(15#&V) 15 psi/-14.7psi																																					
(750#) 750 psi	(30#&V) 30 psi/-14.7psi																																					
(1000#) 1000 psi	(45#&V) 45 psi/-14.7psi																																					
(2000#) 2000 psi	(60#&V) 60 psi/-14.7psi																																					
NOTES ON VARIATIONS:																																						
- When applicable, "X" or "#" codes will be part of the product code.																																						
- If multiple x-variations are ordered, only one 'x' is to precede the variations listed and the variations are to be listed in alpha numeric order based on the first character.																																						
- Additional "X" variations are available, consult factory.																																						
- Pressure ranges 20,000 psi (1380 bar) or higher require F09 (9/16-18 AMINCO) or MD2 (1/4 NPTF male fitting).																																						

Type DG25 General Purpose Digital Gauge

RANGE CODE	PSI		bar		In. Hg		cm Hg.		mm Hg.		kPa		mPa		kg/cm ²		ft H ₂ O		
	Low Range	High Range	Low Range	High Range	Low Range	High Range	Low Range	High Range	Low Range	High Range	Low Range	High Range	Low Range	High Range	Low Range	High Range	Low Range	High Range	
0I#&V*	Vacuum -14.500		0	-9998	0	-29.52	0	-74.99	0	-749.9	0	-99.97	0	-10000	0	-1.0195	0	-33.46	0
15#&V*	Compound -14.50		15.00	-9998	1.0342	-29.52	30.54	-74.99	77.57	-749.9	775.7	-100.0	103.4	-1000	.1034	-1.0195	1.0546	-33.46	34.62
30#&V*	-14.50		30.00	-1.000	2.0685	-29.52	61.08	-74.99	155.15	-749.9	1551.5	-100.0	206.8	-1000	.2068	-1.019	2.109	-33.46	69.23
60#&V	-14.50		60.00	-1.000	4.137	-29.52	122.16	-75.0	310.3	-750	3103	-100.0	413.7	-1000	.4137	-1.019	4.219	-33.46	138.46
100#&V	-14.50		100.00	-1.000	6.895	-29.5	203.6	-75.0	517.2	-750	5172	-100.0	689.5	-1000	.6895	-1.019	7.031	-33.5	230.8
300#&V	-14.5		300.0	-1.000	20.685	-29.5	610.8	-75.0	1551.5	-750	15515	-100.0	2068.4	-1000	2.0684	-1.019	21.093	-33.5	692.3
15#*	Pressure 0		15.000	0	1.0342	0	30.54	0	77.57	0.0	775.7	0	103.42	0	.1034	0	1.0546	0	34.62
30#	0		30.00	0	2.0685	0	61.08	0	155.15	0.0	1551.5	0	206.84	0	.2068	0	2.1093	0	69.23
60#	0		60.00	0	4.137	0	122.16	0	310.3	0	3103	0	413.7	0	.4137	0	4.219	0	138.46
100#	0		100.00	0	6.895	0	203.60	0	517.2	0	5172	0	689.5	0	.6895	0	7.031	0	230.77
200#	0		200.00	0	13.790	0	407.2	0	1034.3	0	10343	0	1378.9	0	1.3789	0	14.062	0	461.5
300#	0		300.0	0	20.685	0	610.8	0	1551.5	0	15515	0	2068.4	0	2.0684	0	21.093	0	692.3
500#	0		500.0	0	34.47	0	1018.0	0	2586	-	-	0	344.7	0	3.447	0	35.15	0	1153.8
1000#	0		1000.0	0	68.95	0	2036.0	0	5172	-	-	0	689.5	0	6.895	0	70.31	0	2307.7
1500#	0		1500.0	0	103.42	0	3054	0	7757	-	-	0	1034.2	0	10.342	0	105.46	0	3462
2000#	0		2000.0	0	137.90	0	4072	0	10343	-	-	0	1378.9	0	13.789	0	140.62	0	4615
3000#	0		3000	0	206.85	0	6108	0	15515	-	-	0	20684	0	20.684	0	210.93	0	6923
5000#	0		5000	0	344.7	0	10180	-	-	-	-	0	344.7	0	351.5	0	351.5	0	11538
10000#	0		10000	0	689.5	0	20360	-	-	-	-	0	689.5	0	689.5	0	703.1	0	23077
15000#	0		15000	0	1034.2	-	-	-	-	-	-	0	1034.2	0	1054.6	-	-	-	-
20000# ⁽¹⁾	0		20000	0	1379.0	-	-	-	-	-	-	0	1378.9	0	1406.2	-	-	-	-
25000# ⁽¹⁾	0		25000	0	1723.7	-	-	-	-	-	-	0	172.37	0	1757.7	-	-	-	-

RANGE CODE	bar		PSI		In. Hg		cm Hg.		mm Hg.		kPa		mPa		kg/cm ²		ft H ₂ O		
	Low Range	High Range	Low Range	High Range	Low Range	High Range	Low Range	High Range	Low Range	High Range	Low Range	High Range	Low Range	High Range	Low Range	High Range	Low Range	High Range	
0BR&V*	Vacuum -1.000		0	-14.50	0	-29.53	0	-75.01	0	-750.1	0	-100.00	0	-10000	0	-1.0197	0	-33.52	0
1BR&V*	Compound -1.00		1.00	-14.50	14.50	-29.53	29.53	-75.01	75.01	-750.1	750.1	-100.00	100.00	-1000	.1000	-1.0197	1.0197	-33.52	33.52
1.6BR&V*	-1.00		1.60	-14.50	23.01	-29.53	47.25	-75.01	120.01	-750.1	1200.1	-100.00	160.00	-1000	.1600	-1.020	1.632	-33.52	53.63
4BR&V	-1.00		4.00	-14.50	58.01	-29.53	118.12	-75.0	300.0	-750	3000	-100.00	400.00	-1000	.4000	-1.020	4.079	-33.52	134.08
6BR&V	-1.00		6.00	-14.50	87.02	-29.5	177.18	-75.0	450.0	-750	4500	-100.00	600.00	-1000	.6000	-1.020	6.118	-33.5	201.1
16BR&V	-1.00		16.00	-14.50	232.10	-29.5	472.5	-75.0	1200.1	-750	12001	-100.00	1600.00	-1000	1.6000	-1.020	16.315	-33.5	536.3
1BR*	Pressure 0		1.0000	0	14.503	0	29.53	0	75.01	0.0	750.1	0	100.00	0	.10000	0	1.0197	0	33.52
1.6BR*	0		1.6000	0	23.205	0	47.25	0	120.01	0	1200.1	0	160.00	0	.16000	0	1.6315	0	53.63
2.5BR	0		2.500	0	36.25	0	73.83	0	187.52	0	1875	0	250.0	0	.2500	0	2.549	0	83.80
4BR	0		4.000	0	58.01	0	118.12	0	300.0	0	3000	0	400.0	0	.4000	0	4.079	0	134.08
6BR	0		6.000	0	87.02	0	177.18	0	450.0	0	4500	0	600.0	0	.6000	0	6.118	0	201.12
10BR	0		10.000	0	145.03	0	295.3	0	750.1	0	7500.6	0	1000.0	0	1.0000	0	10.297	0	335.2
16BR	0		16.000	0	232.05	0	472.5	0	1200.1	0	12001	0	1600.0	0	1.6000	0	16.315	0	536.3
25BR	0		25.00	0	362.5	0	738	0	1875.2	0	18752	0	2500	0	2.5000	0	25.49	0	838.0
40BR	0		40.00	0	580.1	0	1181.2	0	3000	-	-	0	4000	0	4.000	0	40.79	0	1340.8
60BR	0		60.00	0	870.2	0	1771.8	0	4500	-	-	0	6000	0	6.000	0	61.18	0	2011.2
100BR	0		100.00	0	1450.3	0	2953	0	7500	-	-	0	10000	0	10.000	0	101.91	0	3352
160BR	0		160.00	0	2320.5	0	4725	0	12001	-	-	0	16000	0	16.000	0	163.15	0	5363
250BR	0		250.0	0	3626	0	7383	0	18752	-	-	0	2500	0	25.00	0	254.9	0	8380
400BR	0		400.0	0	5801	0	11812	-	-	-	-	0	4000	0	40.00	0	407.9	0	13408
600BR	0		600.0	0	8702	0	17718	-	-	-	-	0	6000	0	60.00	0	611.8	0	20112
1000BR	0		1000.0	0	14503	-	-	-	-	-	-	0	10000	0	100.00	0	1019.7	-	-
1600BR ⁽¹⁾	0		1600.0	0	23205	-	-	-	-	-	-	0	16000	0	1631.5	-	-	-	-

* 0.5% accuracy only.

⁽¹⁾ Requires use of pressure connection F09 or MD2

Note “-” in range table indicates unit of pressure is not included in this pressure range.